

STANDARD TD-107 WITH OPTIONAL QUICK DISCONNECT CABLES

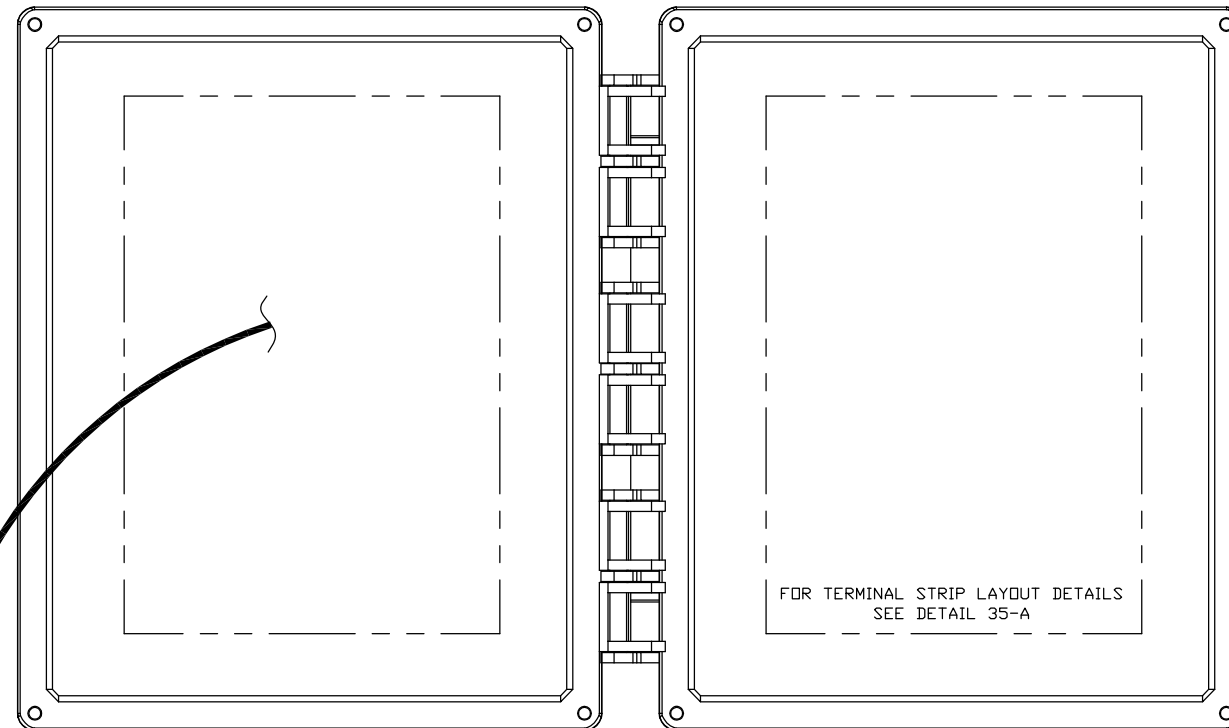

FOR TERMINAL STRIP LAYOUT DETAILS  
SEE DETAIL 35-A

INTERNAL WIRING SCHEDULE	
TB5	CELL ALARM RELAY A: COM
TB6	CELL ALARM RELAY A: NO
TB7	CELL ALARM RELAY A: NC
TB8	ZERO ALARM RELAY A: COM
TB9	ZERO ALARM RELAY A: NO
TB10	ZERO ALARM RELAY A: NC
TB11	SYSTEM ALARM RELAY A: COM - BLK
TB12	SYSTEM ALARM RELAY A: NO - DRG/BLK
TB13	SYSTEM ALARM RELAY A: NC
TB14	HIGH ALARM RELAY A: COM - WHT/BLK
TB15	HIGH ALARM RELAY A: NO - BLK/WHT
TB16	HIGH ALARM RELAY A: NC - GRN/BLK
TB17	EARLY ALARM RELAY A: COM - RED/BLK
TB18	EARLY ALARM RELAY A: NO - BLU/BLK
TB19	EARLY ALARM RELAY A: NC - GRN/YLW
TB1	- BILGE/SEPARATOR - RED
TB2	+ BILGE/SEPARATOR INPUT: 3-28VDC, 100uA/ OR CONTINUITY BETWEEN TB1 & TB2 - BLK
TB3	- SAMPLE/FLOW
TB4	+ SAMPLE/FLOW INPUT: 3-28VDC, 100uA / OR CONTINUITY BETWEEN TB3 & TB4
J5/4	POWER INPUT, 20-240 VAC OR VDC, 15 WATTS, 50/60 Hz (L1), DC+ WHT
J5/5	POWER INPUT, 20-240 VAC OR VDC, 15 WATTS, (L2), DC - BLK
J5/6	POWER INPUT: (AC GROUND) GRN
J9/I	+ ACTIVE ISOLATED: 4-20mA, MAX LOAD 500 OHMS, INTERNALLY POWERED*
J9/J	- ACTIVE ISOLATED: 4-20mA, MAX LOAD 500 OHMS, INTERNALLY POWERED*
J9/F	GND
J9/G	MAINTENANCE ALARM
J9/H	MAINTENANCE ALARM RETURN

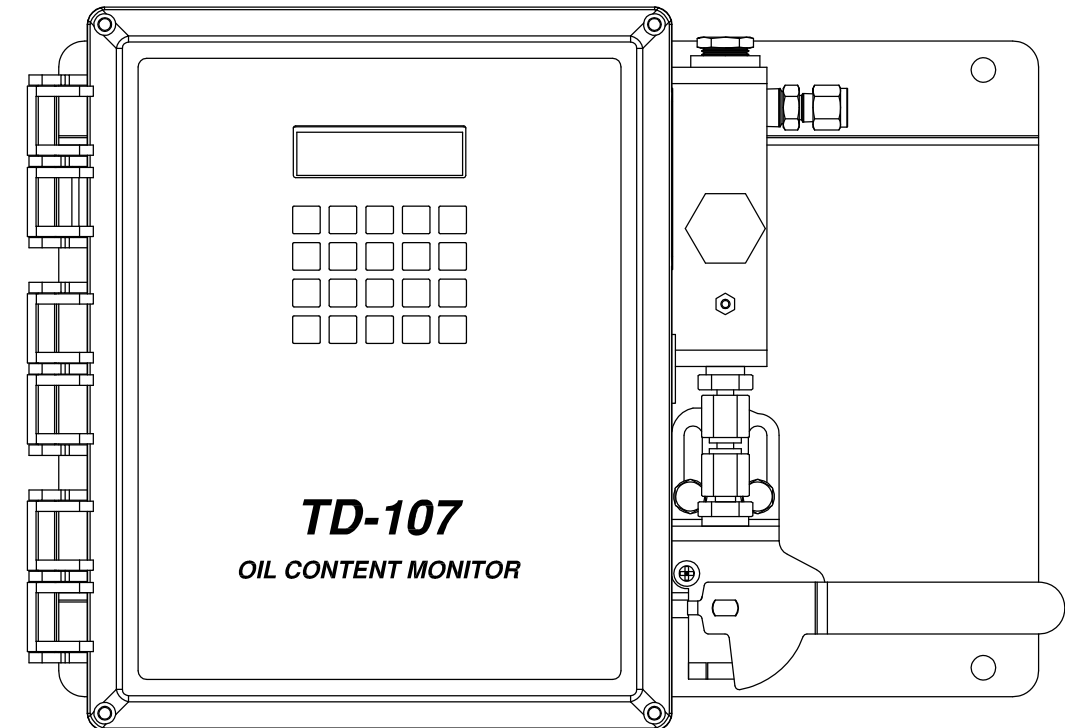
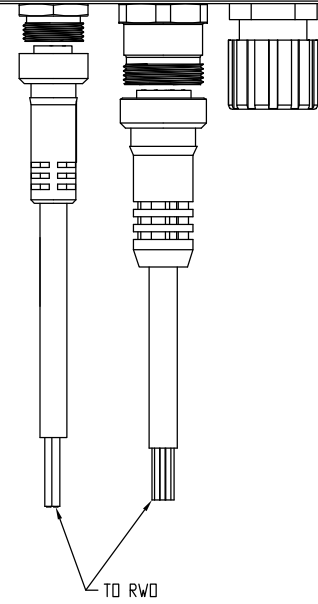

**TD-107**  
OIL CONTENT MONITOR

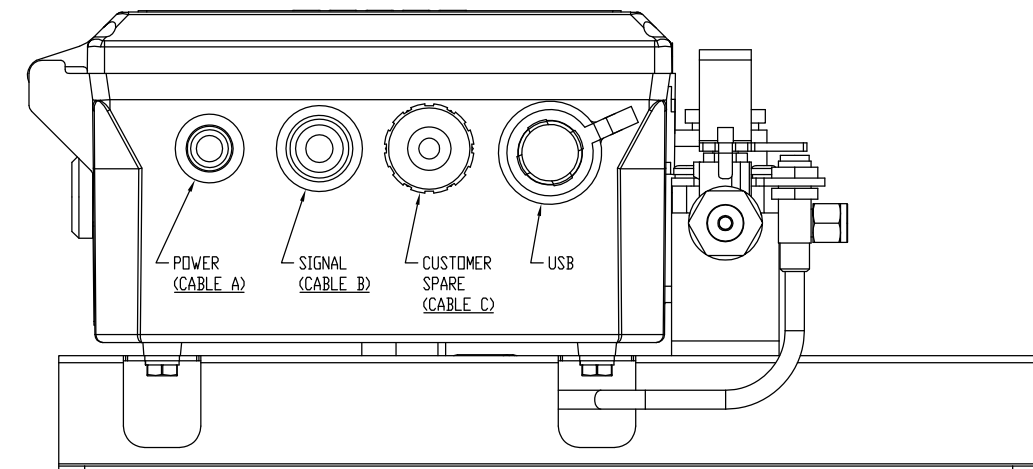

LIST OF MATERIAL (QUANTITY FOR ONE SHIP)												
ITEM NO	QTY	DESCRIPTION	MIC LVL	PP CL	CAST CAT	MATERIAL SPEC	MATERIAL	NSN OR MFG PART NO	SCE	APL NO	UNIT WT	REMARKS
1	1	TD-107, OIL CONTENT MONITOR	-	-	-	-	VARIOUS	P/N TD-107c	IAF	-	-	NAG MARINE
2	1	CABLE, 16/3 YELLOW	-	-	-	-	-	P/N MIN-3CBL-C	IAF	-	-	NAG MARINE
3	1	3 PDL MALE RECP 1/2" NPT, 6AWG	-	-	-	-	-	P/N MIN-3MR-1	IAF	-	-	NAG MARINE
4	1	3 PDL FEMALE PLUG 16AWG	-	-	-	-	-	P/N MIN-3FP-6	IAF	-	-	NAG MARINE
5	1	CABLE, 12 CONDUCTOR, 18AWG COPPER, STRANDED	-	-	-	-	-	P/N MIN-12CBLX-C	IAF	-	-	NAG MARINE
6	1	12 PDL MALE RECP 18AWG	-	-	-	-	-	P/N MIN-12MR-1-18	IAF	-	-	NAG MARINE
7	1	12 PDL FEMALE PLUG 300V 18AWG	-	-	-	-	-	P/N MIN-12FPX-6	IAF	-	-	NAG MARINE
8	2	NUT, LOCK, 1/2" NPT	-	-	-	-	STEEL	P/N 212M	IAF	-	-	NAG MARINE

SIZE	CAGE CODE	DATE	DRAWING NO.	REV
F	-	-	NAG-TD107-W/CABLE	-
SCALE: 1" = 1'				SHEET X

